

Montagehandleiding / Instructions de montage
Montagehinweis / Mounting instructions

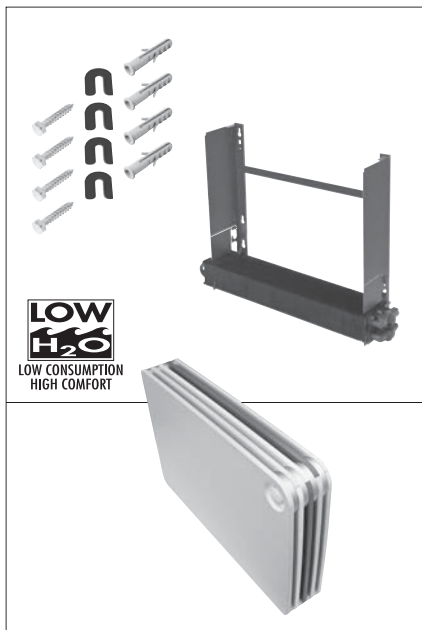

AFMETINGEN DIMENSIONS
ABMESSUNGEN DIMENSIONS

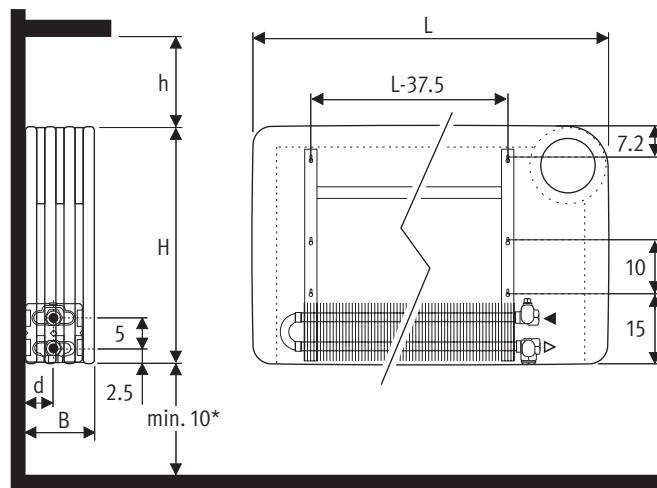

| DIMENSIONS (cm) | | | |
|-----------------|----|------|--------|
| Type | B | d | h min* |
| 10-11 | 13 | 5.2 | 10 |
| 15-16 | 18 | 7.7 | 12 |
| 20-21 | 23 | 10.2 | 15 |

- * Kleinere afstanden kunnen een lichte daling van de afgifte tot gevolg hebben.
- * Des dimensions inférieures peuvent diminuer légèrement l'émission de chaleur.
- * Kleinere Abstände verändern geringfügig die Wärmeleistung.
- * Smaller dimensions can decrease output.



HYDRAULISCHE AANSLUITING - RACCORDEMENT HYDRAULIQUE
HYDRAULISCHER ANSCHLUSS - HYDRAULIC CONNECTION

Verticaal Jaga thermostaatventiel met geïntegreerde bediening
Vanne thermostatique Jaga vertical avec commande intégrée
Vertikales Jaga Thermostatventil mit Integriertem Bedienung
Vertical Jaga thermostatic valve with integrated control

Naar de wand met Jaga Pro ventiel
Vers le mur avec vanne Jaga Pro
Zur Wand mit Jaga Pro Ventil
To the wall with Jaga Pro valve

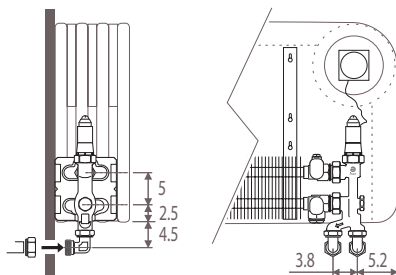

Naar de wand met Jaga dubbel haaks ventiel
Vers le mur avec vanne Jaga double équerre
Zur Wand mit Jaga doppeleckform Ventil
To the wall with Jaga double angled valve

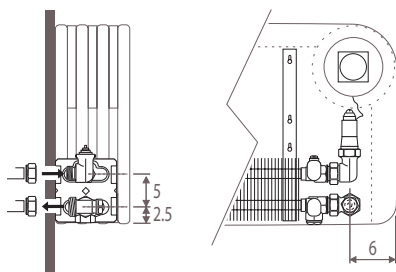

Naar de vloer met Jaga Pro ventiel
Vers le sol avec vanne Jaga Pro
Zum Boden mit Jaga Pro Ventil
To the floor with Jaga Pro valve

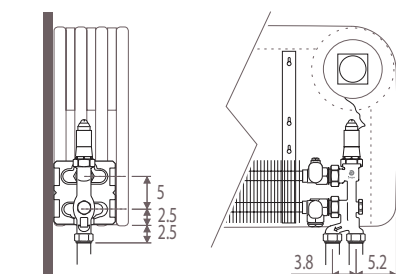

OPTIE
OPTION

Montage onderrooster
Montage grille de base
Montage Bodenschutzrost
Mounting base grille

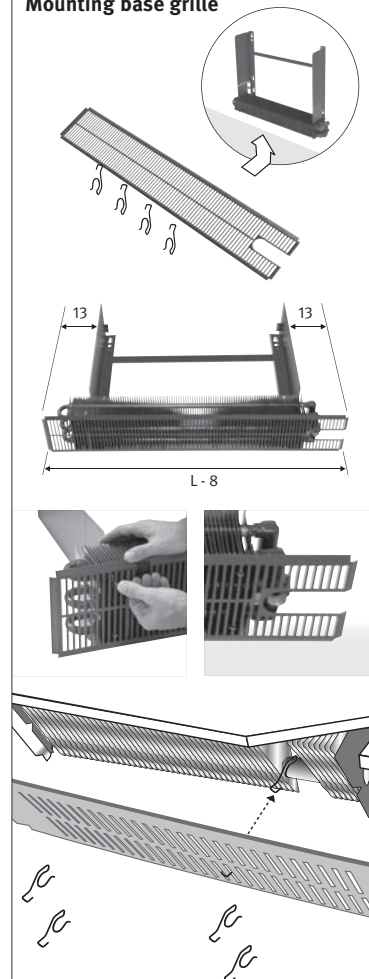

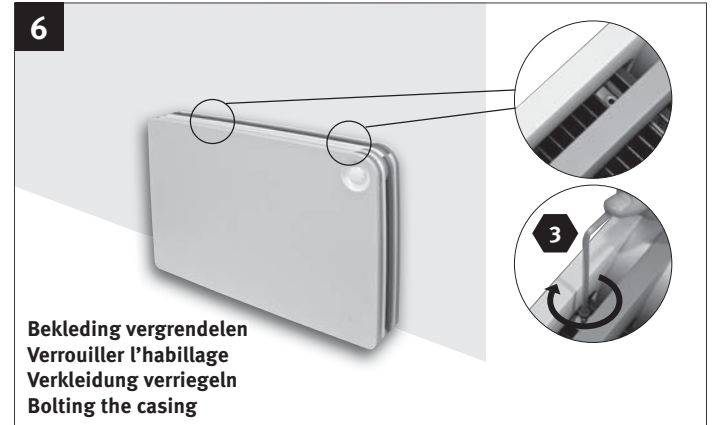
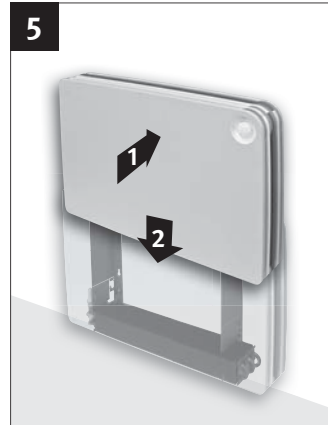
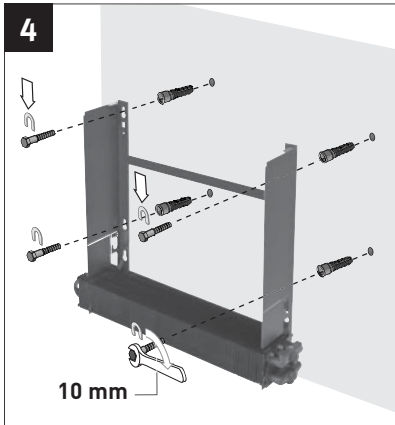
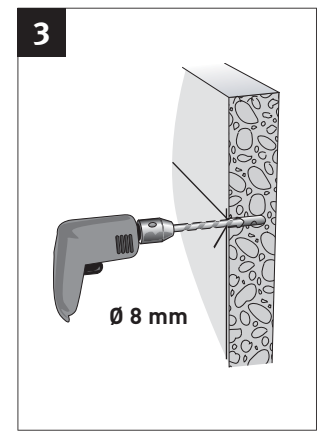
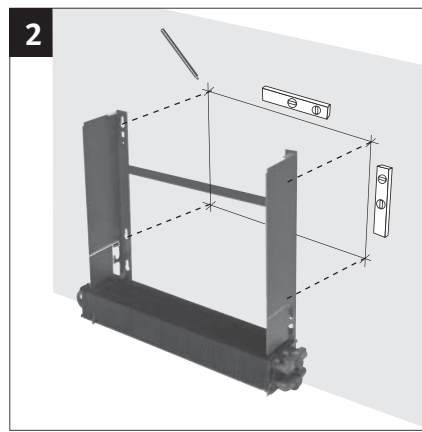
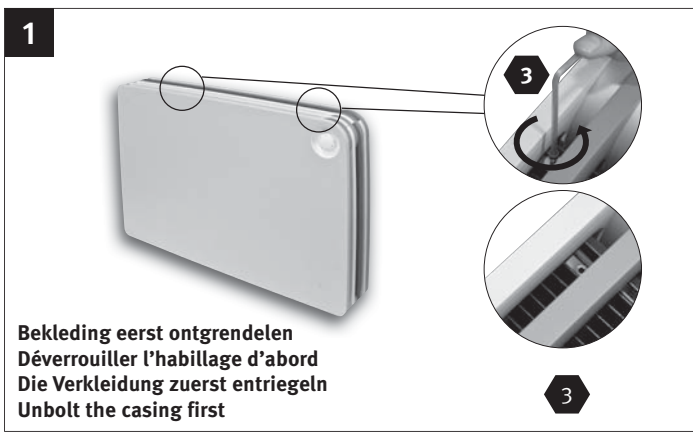

OPTIE_OPTION VENTIEL_VANNE_VENTIL_VALVE

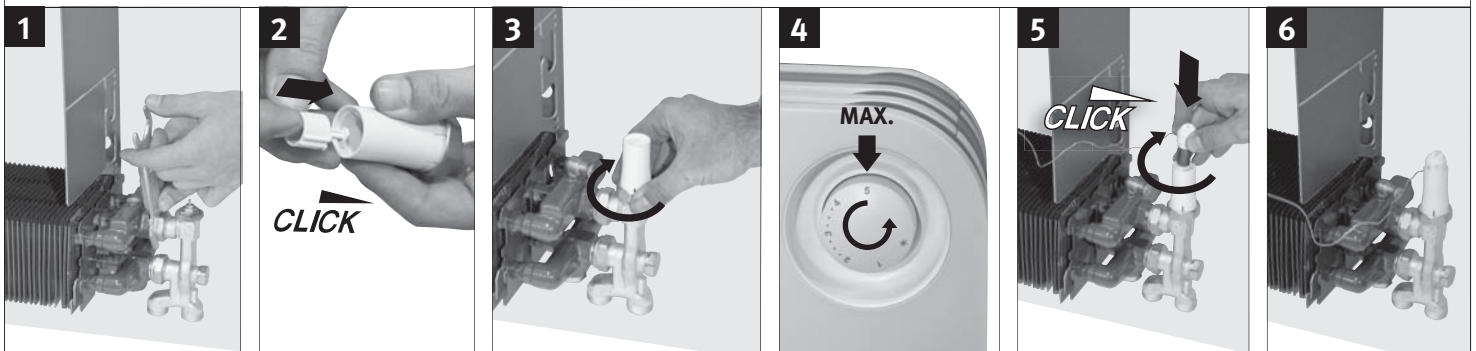

BEGRENZING EN BLOKKERING VAN HET INSTELBEREIK_LIMITATION ET BLOCAGE DE LA ZONE DE RÉGLAGE
BEGRENZUNG UND BLOCKIERUNG DES BEREICHS_LIMITING AND BLOCKING THE SETTING RANGE

Begrenzing van de min. temperatuur
Limitation de la température min.
Einstellungsbegrenzung der min. Temp.
Limiting the min. temperature



Begrenzing van de max. temperatuur
Limitaion de la température max.
Einstellungsbegrenzung der max. Temp.
Limiting the max. temperature



Blokkering wordt ingesteld door het combineren van de bovenste en onderste grens instelling.

Le verrouillage se fait en combinant la limite supérieure et inférieure de réglage.

Die Blockierung erfolgt durch die Kombination des oberen und unteren Limits.

Lock setting is done by combining the upper and lower limiter setting.

